

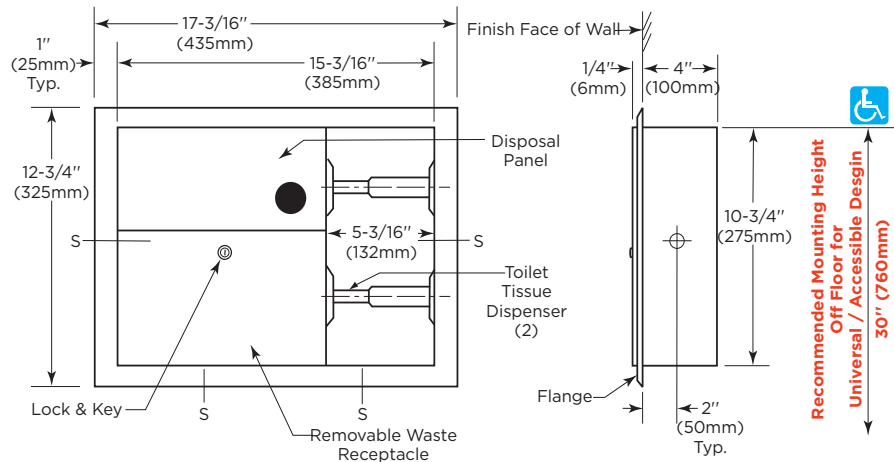

## Technical Data

# CLASSICSERIES® RECESSED SANITARY NAPKIN DISPOSAL AND TOILET TISSUE DISPENSER

# B-3094



### Rough Wall Opening

15-5/8" (395mm) wide  
11-1/4" (285mm) high  
4" (100mm) minimum  
recessed depth

### MATERIALS:

**Cabinet** — 18-8, type-304, heavy-gauge stainless steel. All-welded construction.

**Flange** — 18-8, type-304, 22-gauge (0.8mm) stainless steel with satin finish. Drawn and beveled, one-piece, seamless construction.

**Disposal Panel** — 18-8, type-304, 22-gauge (0.8mm) stainless steel with satin finish. Self-closing panel is secured to cabinet with a spring-loaded, full-length stainless steel piano-hinge and equipped with an international graphic symbol identifying napkin disposal.

**Waste Receptacle** — 18-8, type-304, 22-gauge (0.8mm) stainless steel with satin finish. Equipped with a tumbler lock keyed like other Bobrick washroom accessories. Capacity: 3/4-gal. (2.8-L).

**Toilet Tissue Dispensers (2)** — 18-8, type-304, 22-gauge (0.8mm) stainless steel with satin finish. Equipped with two chrome-plated plastic spindles, each with a heavy-duty internal spring.

### OPERATION:

Unit holds two standard-core toilet tissue rolls up to 5-1/4" (135mm) diameter (1800 sheets). Receptacle unlocks with key provided and slides out for servicing.

*Designer's Note:* It is recommended that one full toilet tissue roll remain wrapped until the other roll has been depleted to avoid wasting ends of both rolls.

### INSTALLATION:

Provide framed rough wall opening 15-5/8" wide x 11-1/4" high (395 x 285mm). Minimum recessed depth required from finish face of wall is 4" (100mm). Allow clearance for construction features that may protrude into rough wall opening from opposite wall. Coordinate with mechanical engineer to avoid pipes, vents, and conduits. Mount cabinet with shims between framing and cabinet at all points indicated by an S, then secure unit with sheet-metal screws furnished by manufacturer.

### SPECIFICATION:

Recessed sanitary napkin disposal and toilet tissue dispenser shall be type-304 stainless steel with all-welded construction; exposed surfaces shall have satin finish. Flange shall be drawn and beveled, one-piece, seamless construction. Self-closing disposal panel shall be secured to cabinet with a spring-loaded, full-length stainless steel piano-hinge and equipped with an international graphic symbol identifying napkin disposal. Removable waste receptacle shall be equipped with a tumbler lock keyed like other Bobrick washroom accessories and shall have a minimum capacity of 3/4-gal. (2.8-L). Unit shall be equipped with two chrome-plated plastic toilet tissue spindles that hold standard-core rolls up to 5-1/4" (135mm) diameter (1800 sheets).

*To specify theft-resistant spindles as an optional accessory, add to specification:* Theft-resistant toilet tissue spindles shall be removable only with special key provided.

**Recessed Sanitary Napkin Disposal And Toilet Tissue Dispenser shall be Model B-3094 of Bobrick Washroom Equipment, Inc., Clifton Park, New York; Jackson, Tennessee; Los Angeles, California; Bobrick Washroom Equipment Company, Scarborough, Ontario; Bobrick Washroom Equipment Pty. Ltd., Australia; and Bobrick Washroom Equipment Limited, United Kingdom.**